

O-ring detail
(Housing & Top Plate)
Scale 1:2

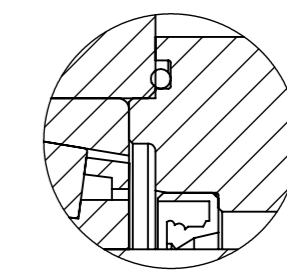

O-ring and Lip seal detail
Scale 1:1

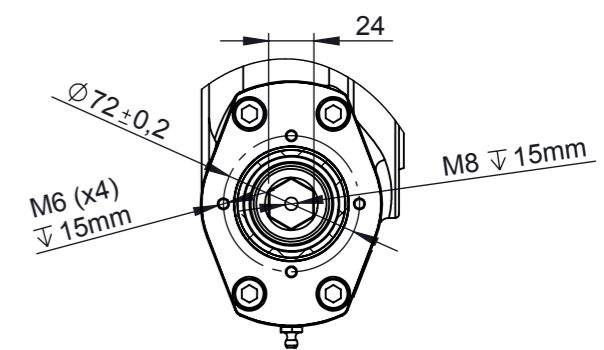

Output shaft detail
Scale 1:5

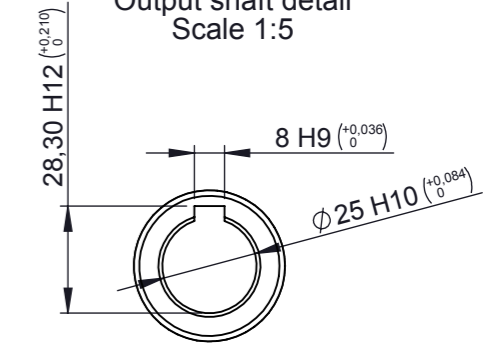

Input shaft detail
Scale 1:2

Main performance parameters

Gear Ratio	85:1	Holding torque	47.5kNm
Efficiency	40%	Tilting moment	67,8kNm
Self-locking gear	Yes	Radial static load	222kN
Backlash clearance	<0,17°	Axial static load	555kN
Maximum torque	21.960Nm	Radial dynamic load	117kN
Nominal torque	18.350Nm	Axial dynamic load	133kN

Notes: All slew drive are pre-lubricated. Maximum output speed 1rpm. Standard paint for corrosion category C3-M - Grey RAL 7040

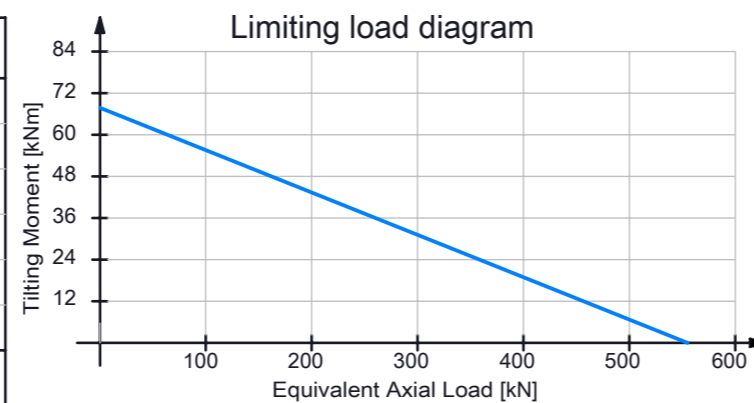

REV.	DESCRIPTION	DATE	NAME	CHECK
B	Changed plug position	22/10/15	G.S	T.D
A	First Design	30/03/15	G.S	T.D

The information contained in this document is property of TGBgroup. It is not allowable any copy or reproduction of this certificated copy with the original not under control. TGBgroup reserve changes of manufacture without previous advice and duty of communication.

>1200	±1,2
>400.0 ~ 1200	±0,8
>120.0 ~ 400.0	±0,5
>30.0 ~ 120.0	±0,3
>6.0 ~ 30.0	±0,2
>3.0 ~ 6.0	±0,1
>0.3 ~ 3.0	±0,1
Range of sizes	Unstated tolerance



TGB GROUP
INFO@TGBGROUP.ES
WWW.TGBGROUP.ES

Reference		TE435-2-Z0-RM		Rev
Denomination		Sales Drawing		B
MATERIAL:	WEIGHT [kg]:	84.35	NUM. PIECES:	1
SCALE:	1:4	SIZE:	A3	SHEET:
				1 of 1